

# GREASE GRABBER® GREASE REMOVAL SYSTEMS



## General Description

The heart of the system features a patented design grease skimmer. Unlike oil skimmers this system was designed and developed specifically to pick up heavy grease and oil. The Grease Grabber® makes use of the differences in specific gravity and surface tension between grease and water. These physical characteristics allow the belt to attract grease, oil, and other hydrocarbon liquids as the belt passes through the surface of the water.

The construction of the Grease Grabber has a rugged simplicity that is designed to last 20 years or longer. It can handle liquids between 32°F and 212°F, with pH between 1 and 13. The motor, reducer, and powder coated finish give the unit exceptionally long life.

Belt tension is maintained by the weight of a free riding tail pulley. The tail pulley is tethered to the underside of the Grease Grabber to prevent accidental loss.

**The system is available in 3 basic configurations\*:**

- **System A:** Basic Grease Grabber System; features the Grease Grabber and Mat Buster
- **System B:** Enhanced Discharge System; features Screw Feed Discharge
- **System C:** Transfer System; features Transfer Package

*\*All systems can be adapted to your application.*

## The Grease Grabber System Advantages

- Removes heavy non-flowing greases and oil from water
- Elevates and removes up to 160 gph of grease over 100 ft. without pumps.
- Reduces fluid disposal costs
- Helps meet government requirements for water discharge
- Protects expensive sand filtration systems
- Operates in freezing temperatures
- Requires only a 28" x 9" (71.12cm x 22.86cm) mounting area
- Maintains skimming efficiency with fluctuating fluid level
- Fast set-up, easy cleaning, and minimal maintenance
- Effectively operates in turbulent liquids

# GREASE GRABBER® GREASE REMOVAL SYSTEMS

## Why The Grease Grabber?

No other system is designed for extremely demanding applications, such as scale pits, where heavy loads of grease and oil accumulate. To handle this kind of load, the Grease Grabber uses an oil-filled gear reducer having bronze gears and ball bearings to drive pressure rolls with tractor treads that rotate the belt. This heavy-duty drive train will elevate skimmed grease over 100 feet for easy discharge into tramp waste containers.

## Typical Applications

- Circulating water systems in steel mills
- Truck, locomotive and other mobile equipment washing facilities
- Wastewater sumps or tanks
- Food processing facilities
- Parking lots, garages, and service facilities



System A in use at a steel mill

## Key Features of the Grease Removal System

- Designed for the most demanding outdoor applications
- Corrosion-resistant materials
- Continuous duty
- All electrical components are UL CSA approved
- Conforms to CE directives
- Innovative safety features
- Customized belt lengths and materials
- 30 day money back guarantee (call for details)

Mat Buster

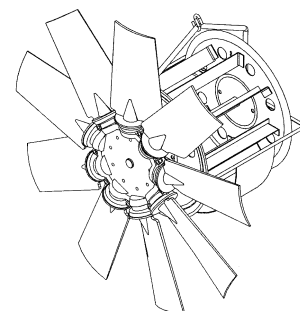

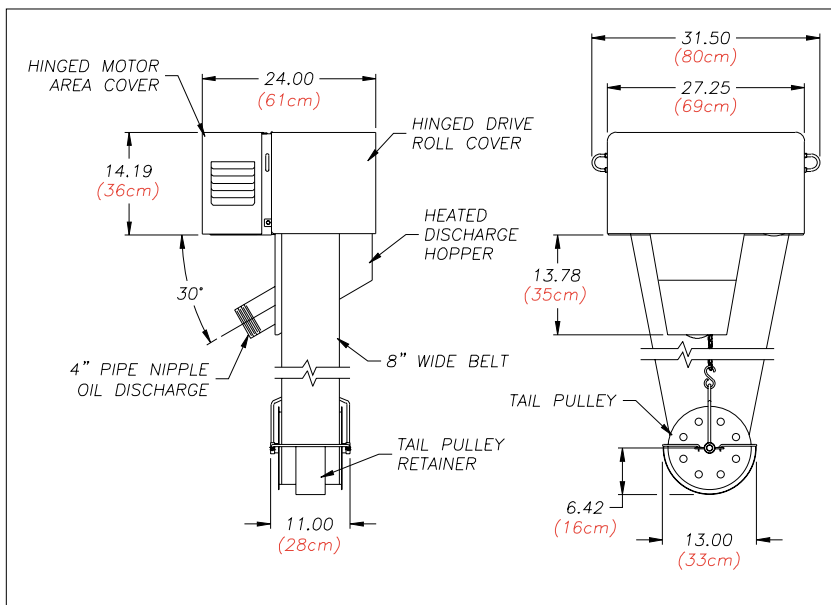

## Specifications:

### System A: Grease Grabber

**Removal Rate:** 160 gph (606 lph)  
*Actual removal rate will vary with application.*  
 (Removal rate is based on Brooks Technology Plexelene 750™ grease and other components in ordinary water.)  
 Solid welded carbon steel with a baked on powder coat finish. Color: Dark safety blue.

#### Construction

Motor

Heater

Belt Width

Belt Length

Belt Material

Wiper

Mounting Method

Fractional hp, TEFC, 115/230 VAC, single phase, 60Hz.  
 2200 W  
 8 inches (20.3 cm)  
 User specified (Call factory)  
 Woven textured polyester  
 Hybrid ceramic impregnated polypropylene  
 Flat surface mount is standard. 2" steel angle frame 20" high clearance for flat surface mounting and shipping.  
 Custom mounting stands available.

#### Mounting Area

Appx. 28" X 10" (71.12cm x 22.86cm).

See installation drawing.

#### Weights

Complete drive unit without tail pulley or belt:  
 Approximately 240 lbs. (109 kg) - two lifting hooks installed on drive unit

Tail pulley: 10 lbs. (4.5 kg)

Mat Buster: 10lbs. (4.5 kg)

### Mat Buster

24" or 36" dia. blades - Requires additional tail pulley clearance requirements:

24" Blade 18" x 28"

36" Blade 20" x 40"

### System B:

#### Grease Grabber

See Grease Grabber specs under system A.

#### Screw Feed Discharge

Motor

1/4hp, 115/208-230 VAC, 1 PH, 60Hz.  
 5/2.6-2.5 Amps, 56C-Face, TEFC, 1725RPM

Gear Reducer

48:1 right angle

Auger

4" right hand helical flighting welded to 1-1/4" sch-40 pipe.

### System C:

#### Grease Grabber

See Grease Grabber specs under system A.

#### Transfer Package

Transfer tank. (Volume User Specified)  
 Transfer tank immersion heater. (Sized to tank)  
 Hinged hood on tank for easy access.  
 Positive displacement pump.  
 Transfer tank level control.

#### Options (Specify)

316 stainless steel housing  
 Screw feed discharge  
 Screw feed "heated" discharge  
 Mat Buster  
 Remote ON/OFF switch  
 Stabilizer bars available for (extreme) turbulent applications  
 Timer  
 Control Panel  
 3-phase electrical

### Standard Configuration

The Abanaki Grease Grabber is supplied with a hinged motor guard, raised by a gas spring when released. An additional guard covers the drive roll area. Other standard componentry includes a fixed wiper blade assembly, skimmer belt and tail pulley. The unit comes with assembly instructions.



### System A

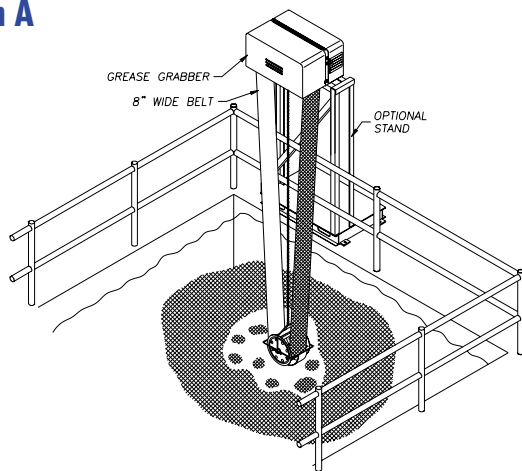

### System B

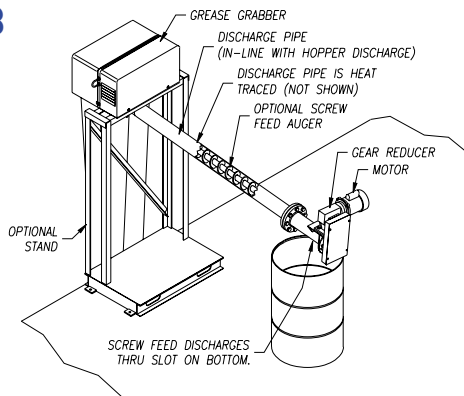

### System C

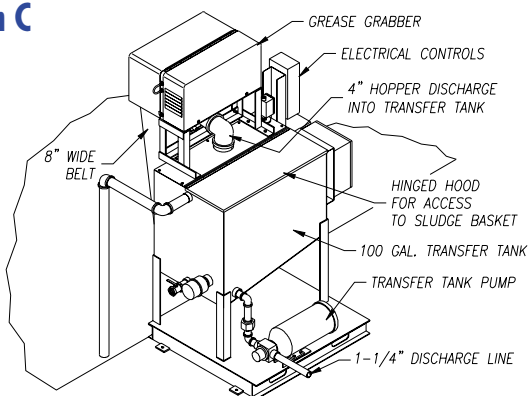



## Other Oil Skimming Products From Abanaki:

### Abanaki Oil Skimmer Quick Selector Chart

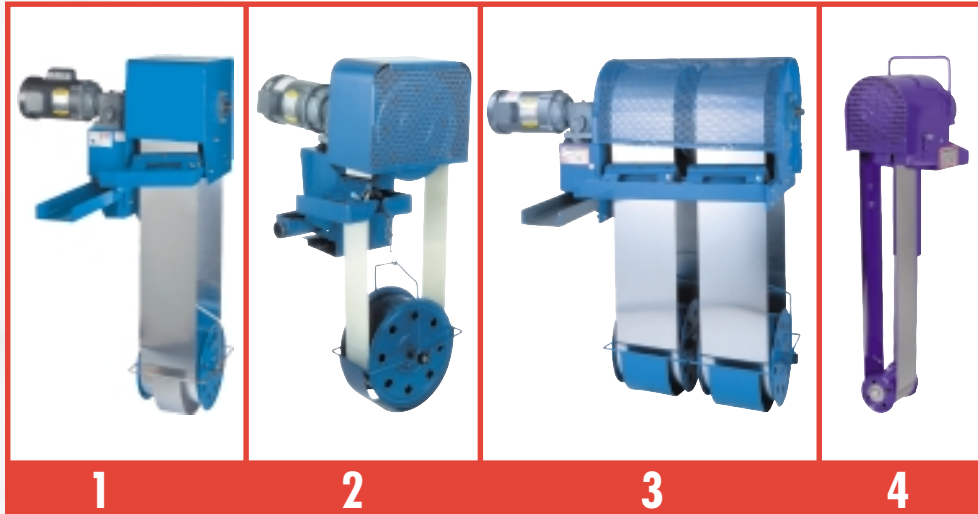

1. **For Most Applications:**  
OIL GRABBER® MODEL 8<sup>2</sup>  
Single 8-inch wide belt (20.3 cm)  
Any length belt  
Capacity: 40 GPH (151.4 LPH)
2. **When Model 8 Oil Grabber® Is Too Large:**  
OIL GRABBER® MODEL 4  
Single 4-inch wide belt (10.2 cm)  
Any length belt  
Capacity: 20 GPH (75.7 LPH)
3. **For High Volume Use:**  
OIL GRABBER® MULTI-BELT  
Two to five 8-inch belts (20.3 cm)  
Any length belts  
Capacity: to 600 GPH (2271 LPH)
4. **For Small Size, Small Capacity, Or Multi-Tank Use:** TOTE-IT® PORTABLE  
Single belt: 2-inch or 4-inch (5.1 or 10.2 cm)  
Belt length: 1' - 6" to 5' - 0" (45.2 to 152.4 cm)  
Capacity: 6 GPH - 2" belt (15.1 LPH - 5.1 cm belt)  
7 GPH - 4" belt (22.7 LPH - 10.2 cm belt)



# GREASE GRABBER® GREASE REMOVAL SYSTEMS

**For more information, please contact:**



**WMI Wolfgang Moik  
Industrieprodukte**

Hauptstr. 31 A-5082 Grödig / Austria

Telefon +43-6246-73 412

Telefax +43-6246-73 412-22

office@wmi.co.at

www.wmi.co.at

*Plexelene 750™ by Brooks Technology Co.  
Optional Equipment Shown In Some Views.*

© Abanaki Corporation, 1999