

A B A N A K I

MIGHTY MINI[®] SST



The ideal solution to remove unwanted oil in coolants & parts washers!

Effective. Removes one (1" wide belt) or two (2" wide belt) gallons or more of medium weight oil per hour. **Compact.** Use it almost anywhere...even through a 2" dia. bunghole in a drum. **Portable.** Use it here today, there tomorrow. Weights only 7 pounds, installs in seconds and runs on 110 v. power. 220v motor available. **Complete.** Put it to work right out of the box, or add the optional, easy-to-install decanter and brackets for an even more efficient system.



Durable. Includes long life fan-cooled motor, sturdy 304 stainless steel construction with integrated 24 hour timer. **30-day Money Back Guarantee.** Every Abanaki skimmer is backed as well as it's built. We do it right or you don't pay!

WMI

**WMI Wolfgang Moik
Industrieprodukte**

Hauptstr. 31

A-5082 Grödig / Austria

Telefon +43-6246-73 412

Telefax +43-6246-73 412-22

office@wmi.co.at

www.wmi.co.at

Abanaki Mighty Mini® SST Oil Skimmers & Accessories

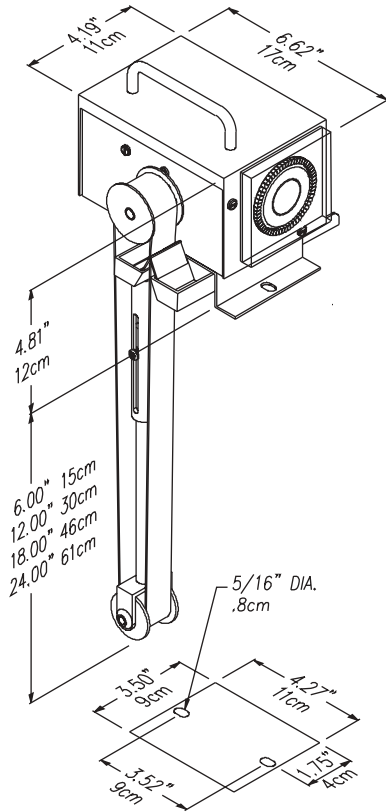

Mighty Mini® Skimmers

- ▶ Fan-cooled motor
- ▶ 1" and 2" wide stainless steel or specially-engineered plastic belts
- ▶ Both sides of belt are wipes for better efficiency
- ▶ 304 stainless steel base and housing
- ▶ Spring-loaded stabilizer bar
- ▶ 3-foot clear discharge hose and clamp
- ▶ 8-foot grounded power cord w/plug
- ▶ Integrated 24 hour timer

Models Available:

(Depth is measured from the bottom of the mounting base to the bottom of the tail pulley)

Belt	1" (25.4mm)	2" (50.8mm)
Capacity	1gph (3.8lph)	2gph (5.7lph)
Model	MM 100ST-06	MM 200ST-06
		6" (152mm)
Model	MM 100ST-12	MM 200ST-12
		12" (152mm)
Model	MM 100ST-18	MM 200ST-18
		18" (152mm)
Model	MM 100ST-24	MM 200ST-24
		24" (152mm)

Standard Mighty Mini® skimmers require 110v., 60-cycle electrical power. Models for 220v., 50-cycle are available.

Easy-Mount Skimmer Bracket

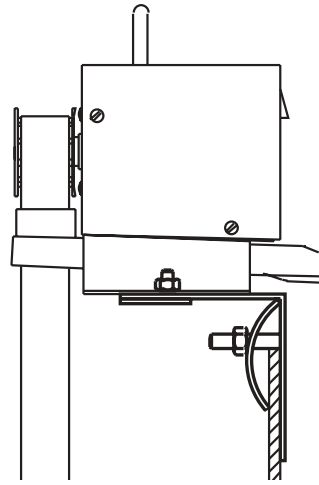

For vertical wall tanks

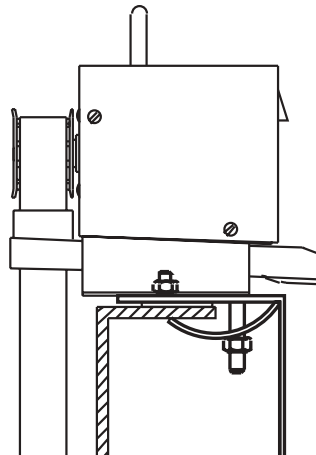

For flanged tanks



Mounting bracket clamps easily to vertical tank wall or horizontal flanged surface to provide fast, secure installation of skimmer.

Dual Position mounting bracket
Model OMMST 100



Coolant Saving Decanter

Decanters save money and improve efficiency by almost completely separating any coolant from the skimmed tramp oils. Oil-free coolant discharged from the decanter is returned to the original tank or directed to a separate container. Virtually no costly coolant gets thrown out with the tramp oil, and coolant-free oil is discharged for disposal.



Decanter Assembly (Includes Adapter Bracket)
Model DM 100

Decanter Hose Kit

Two 5-foot lengths of discharge hose, one for oil and one for water.

Model ODM 100HK

WMI Wolfgang Moik
Industrieprodukte
Hauptstr. 31 A-5082 Grödig / Austria
Telefon +43-6246-73 412
Telefax +43-6246-73 412-22
office@wmi.co.at www.wmi.co.at