

A B A N A K I

OIL GRABBER® MODEL MB



Enjoy the Benefits of Oil Skimming!

- Most inexpensive way to remove oil from water
- Saves coolants by removing tramp oil
- Conserves parts wash water by removing oily wastes
- Prevents plugging of spray heads and filters
- Reduces fluid disposal costs
- Skimmed oil can be recycled and reused as a lubricant or fuel
- Helps meet government requirements for water discharge

General Description

The Abanaki Model MB Oil Grabber is a dependable and effective means of removing oil from water and water-base solutions. Often, skimming by itself will reduce oil to an acceptable level of water purity. Depending on the characteristics of the liquid, it is possible for the Model MB alone to reduce oil content to less than five parts per million in water. The unit can be used as a pretreatment before filtration, and in conjunction with a coalescing system.

The Model MB utilizes continuous belts and wipers to remove up to 200 gallons of oil per hour from the fluid surface. The belts, operating on a motor and pulley system, run through contaminated liquid to pick up oil from the surface. After traveling over the head pulley, the belts pass through tandem wiper blades where oil is scraped off both sides of each belt and discharged. The tail pulleys have flanges which allow them to roll freely on the inside of the belts without becoming dislodged. These lower pulleys require no bearings and do not need to be fastened to the tank. If turbulent conditions exist, an optional tether and cage assembly prevents the tail pulleys from being dislodged.

Oil skimming makes use of the differences in specific gravity and surface tension between oil and water. These physical characteristics allow the belts to attract oil and other hydrocarbon liquids from the surface of the fluid. The Model MB can be used in tanks with depths as shallow as one foot or as deep as 100 feet.

The Model MB Advantages

- A single unit elevates and separates oil
- Lifts oil any distance without the need of expensive pumps
- Maintains skimming efficiency with fluctuating fluid level
- Can be used in depths as shallow as one foot, or as deep as 100 feet
- Requires no tank modifications in most applications
- Operates in turbulent liquid using optional tail pulley cage and tether assembly
- Easy mounting and fast cleaning, with minimal maintenance

OIL GRABBER® MODEL MB

Where To Use The Model MB

The Model MB is designed for those applications where other skimmers do not provide adequate removal capacity. Multiples of two, three, or five belts are available. From a mere shimmer on top of water to a heavy oil slick, the Model MB performs efficiently, removing up to 200 gallons of oil per hour.

Typical Applications

- Wastewater sumps
- Outdoor ponds, lakes, and basins
- Coolant systems
- Underground tanks
- Food processing plants
- Aircraft service areas and tarmac runoff
- Parking lots, garages, and service facilities
- Truck, locomotive, and other mobile equipment washing facilities

Rugged Construction for Harsh Conditions

The Model MB is designed to last for many years. With the proper configuration it can handle liquid temperatures up to 212°F, and the pH of the fluid can range from 1 to 13. Belts are made of corrosion-resistant steel, carbon steel, or a specially engineered polymer. The skimmer drive includes an oil filled gear reducer with bronze gears and ball bearings. The motor, reducer, and powder coated finish of the weldments give the the Model MB exceptionally long life, even under the harshest conditions.

Key Features of the Model MB:

- Requires only a small area in the tank or sump
- Easy mounting
- High temperature capability
- Chip resistant powder finish
- Hazardous duty and food grade options
- Custom designs and turnkey systems available
- Fast cleaning with minimal maintenance

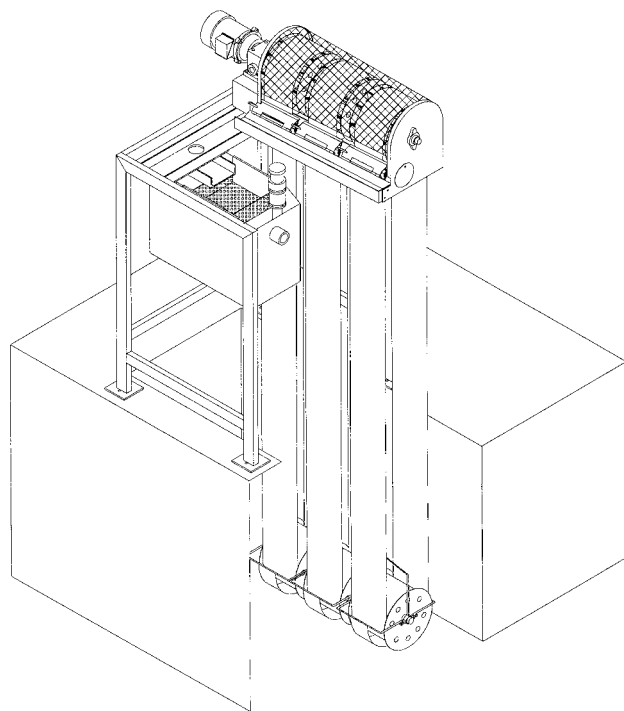

Approximate Oil Removal Rates and installation dimensions for Model MB Skimmers

No. of Belts	Removal Rate, gph (lph)*	A dim., in. (cm)	B dim., in. (cm)	C dim., in. (cm)	D dim., in. (cm)
2	80 (303)	38 (97)	21 1/8 (54)	21 7/8 (54)	15 (38)
3	120 (454)	48 3/4 (124)	31 3/4 (81)	31 1/2 (80)	15 (38)
5	200 (757)	70 (178)	53 (135)	52 3/4 (135)	15 (38)

*Removal Rate is based on 30 weight oil in water

MODEL MB DETAIL

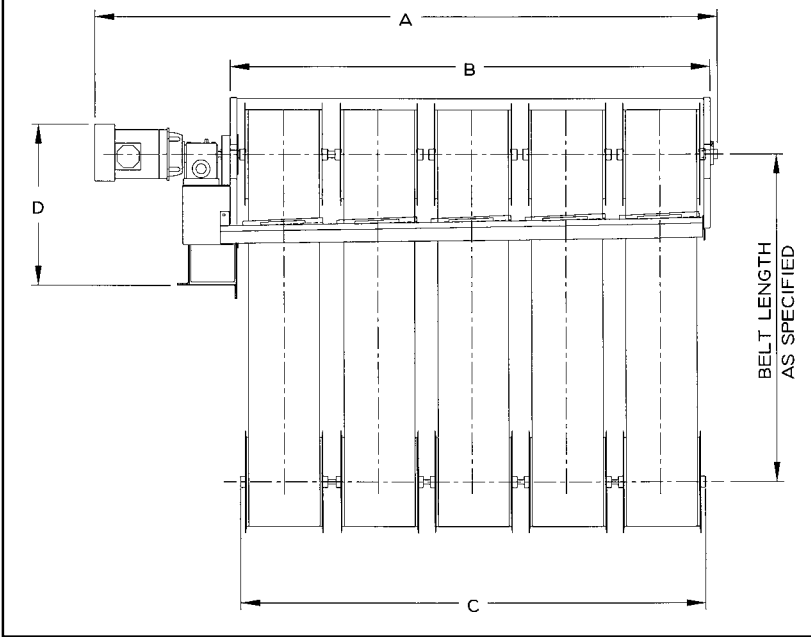

WIPER ASSEMBLY DETAIL

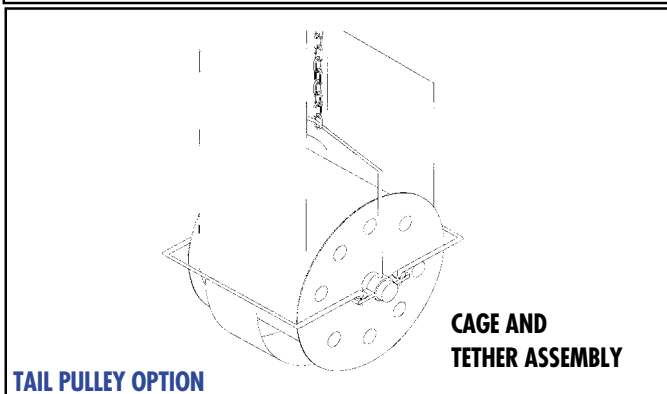
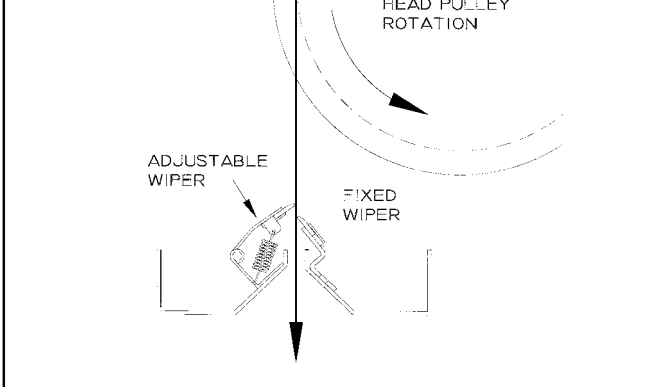

Specifications:

Removal Rate (See Table)
 Tail Pulley Specify standard or high capacity. (The high capacity option uses a patented pulley design that improves the adherence of oil to the inside of the belt, thus increasing the removal rate.)

Motor Fractional, TEFC, gear motor operating on either 115/230VAC, single phase, 60Hz or 230/460 VAC, three phase, 60Hz.

Optional: 50Hz power source; explosion proof; drip proof; pneumatic; and wash down duty motors. 8 in. (20 cm)

Belt Width User specified (see "Belt Selection" next page.)
 Belt Length Specify corrosion-resistant steel, carbon steel, or specially engineered polymer. (See "Belt Selection.")

Belt Material Specify corrosion-resistant steel, carbon steel, or specially engineered polymer. (See "Belt Selection.")

Wiper Nitrile standard; CRV optional. Specify wiper material based on temperature and fluid compatibility. (See "Operating Limits.")

Mounting Method For MB 2x8 and 3x8 — Bracket for 5" steel channel (supplied by customer), with oil discharge through the channel.
 For MB 5x8 — Bracket for 5" square tube (supplied by customer), with oil discharge through the channel.

Weights¹ Drive assembly and housing with motor, without belts or tail pulleys:
 2 belt unit: 74 lbs. (34 kg) max.
 3 belt unit: 86 lbs. (39 kg) max.
 5 belt unit: 110 lbs. (50 kg) max.
 Tail pulley (per belt): 10 lbs. (4.5 kg)
 4 ft. corrosion-resistant steel belt: 7 lbs. (3.2 kg) (belt weight varies according to actual length specified)

- Options (Specify)
- Tail pulley cage and tether assembly for operation in turbulent liquids.
 - Floor mounted support stand.
 - 316 stainless steel housing.
 - Thermostatically controlled heaters (115/230VAC, 900 Watts; the heater hood replaces the standard drive unit cover.)
 - Oil Concentrator[®] for virtually water-free oil (see Abanaki Oil Concentrator[®] on next page.)
 - Float switch with signal light (fits in 3/4" drum bung) to prevent discharge drum overflow.
 - Poly-shelters, reinforced for durable protection in outside applications
 - Timer and electrical controls

Operating Limits
 Wipers²

Temperature of Liquid	pH 1-5 (acidic)	pH 6-8 (neutral)	pH 9-14 (alkaline)
33°F-180°F (0.5°C-82°C)	viton	nitrile	viton
181°F-212°F (83°C-100°C)	viton	viton	viton

Belts²

Temperature of Liquid	pH 1-5 (acidic)	pH 6-8 (neutral)	pH 9-14 (alkaline)
33°F-180°F (0.5°C-82°C)	CR steel, polymer	carbon steel, polymer	polymer
181°F-212°F (83°C-100°C)	CR steel	carbon steel, CR steel	CR steel

Standard Configuration

The standard Model MB is supplied with a motor belt guard, spring-loaded adjustable wiper blade assembly, skimmer belt, tail pulley, and assembly instructions.

Specification Notes:

1. The Model MB is shipped by motor freight.
2. Consult factory for recommendations covering operating conditions not listed here.

Belt Selection

Belt Length

To specify the belt length: Measure from the drive unit mounting plane to the surface of the liquid at its lowest level and add 24 inches (61 cm). (Generally, the lowest level allowed is about one foot, and can never be the bottom of the tank.)

Belt Material

Experience has shown that belt skimmers require a minimum square footage of space for installation and operation, yet they surpass the requirements for most applications. Abanaki single material belts include corrosion-resistant steel (standard), carbon steel, or a specially engineered polymer. There is no delamination to worry about with a single material belt.

Corrosion-resistant Steel - Proven to be a reliable belting material of choice: durable and trouble free. This material stands up to high temperatures and harsh chemicals.

Carbon Steel - Used in applications where the skimmer is operating 24 hours a day or when the liquid has neutral pH.

Engineered Polymer - Used in applications where abrasive particles are present or when physical abuse of the belt is likely.

When in doubt, consult factory for advice on the best belt for your application.

Abanaki has thousands of skimmers installed worldwide at leading companies such as...

American Cyanamid
Armstrong World Industries
Bethlehem Steel
Boeing
Bureau of Reclamation
Caterpillar
Chevron
Corning
Dow Chemical

Eaton
Flying J
Ford Motor
General Electric
Henry Filters
John Deere
Kaiser Aluminum
Mazak
Monroe Auto Equipment

New York Power Authority
Nissan Motor
Outboard Marine
TRW
United Airlines
US Gypsum
US Repeating Arms
USS Great Lakes Fleet
Westinghouse Electric

ABANAKI'S Oil Concentrators®

The Oil Concentrator® is an option available on all ABANAKI oil skimmers. Under most operating conditions ABANAKI oil skimmers will pick up oil with less than 5% water. But as surface oil is reduced to a thin layer (1/16 to 1/8 inches thick), more water or coolant may also be picked up along with the oil. When used in tandem with the oil skimmer, an Oil Concentrator will solve this problem, and provides virtually complete oil /water separation, saving money and improving the efficiency of the skimmer.

Based on the principle of gravity separation, the Oil Concentrator uses no electricity, timers, sensors, pumps, or other moving parts. The Oil Concentrator sits behind the skimmer and receives its discharged oil. The unit comes complete with a mounting bracket, removable sludge screen and a drain plug to ease clean up. For higher viscosity oils or low temperature applications, a thermostatically controlled heater is available as an option.

OIL GRABBER® MODEL MB

For more information, please contact:



**WMI Wolfgang Moik
Industrieprodukte**

Hauptstr. 31

A-5082 Grödig / Austria

Telefon +43-6246-73 412

Telefax +43-6246-73 412-22

office@wmi.co.at

www.wmi.co.at

Optional Equipment Shown In Some Views.

© Abanaki Corporation, 1997