

A B A N A K I

# PetroXtractor® – Well Oil Skimmer

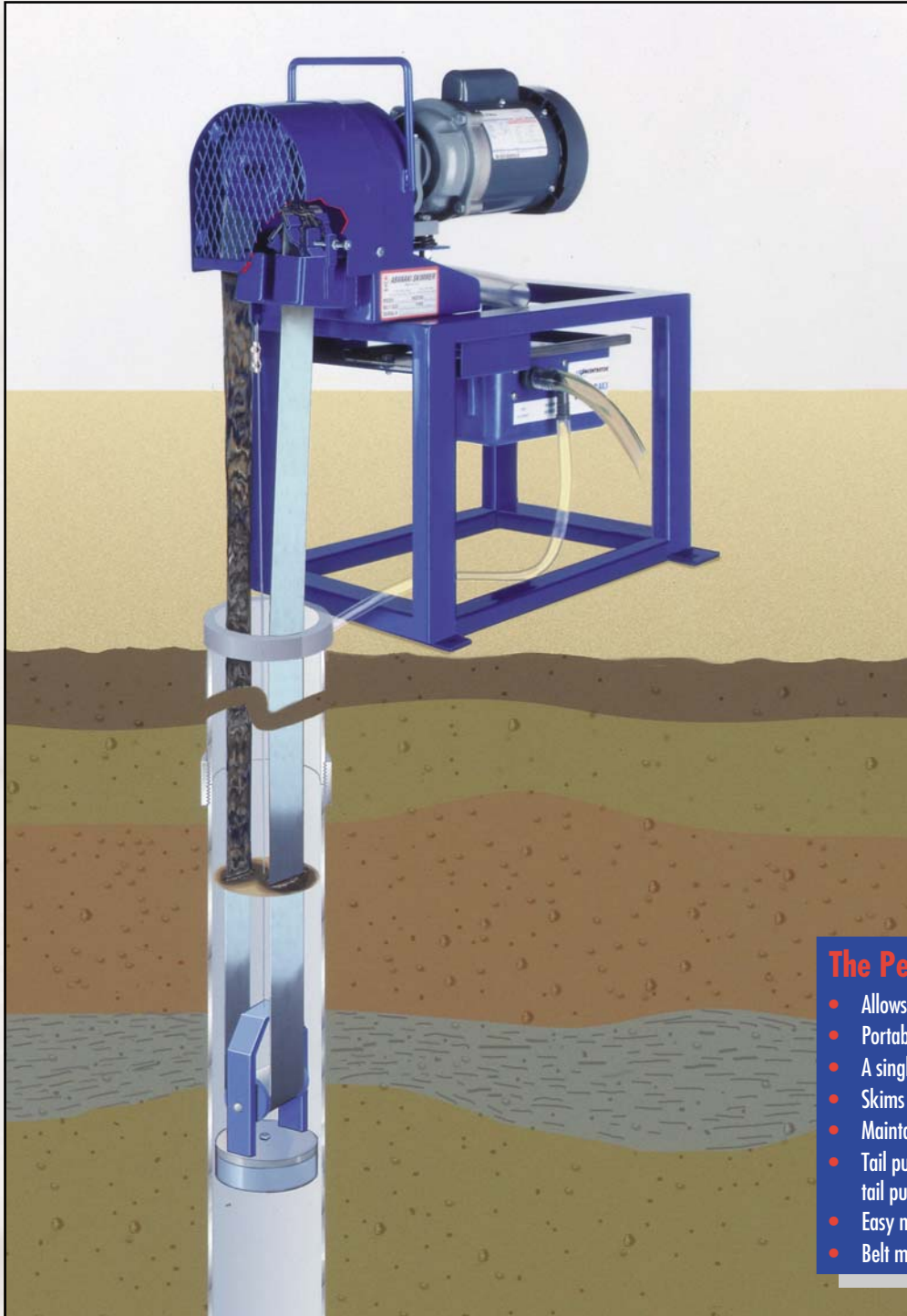

## Oil Skimming for Wells and Other Small Openings

- Ideal for removal of floating oil and other hydrocarbon liquids from existing remediation or monitoring wells
- Can be installed in well casings as small as 2 in. ID
- Elevates skimmed oil 100 feet or more for easy discharge into 55 gallon drum
- Removes up to 12 gph of oil from water

## General Description

The Abanaki PetroXtractor® is a dependable and cost effective means of removing oil, fuel, and other floating hydrocarbons from water where access to the fluid surface is limited. It provides efficient remediation of groundwater contaminated by oil, using existing recovery and monitoring wells. Often, the PetroXtractor® working alone will reduce oil or fuel content to an acceptable E.P.A. level. Models are available for two inch, four inch, and six inch ID well casings, with removal rates up to 12 gph. Depths of 100 feet or more can be accommodated without the use of pumps.

The PetroXtractor® is an oil skimmer that makes use of the differences in specific gravity and surface tension between oil and water. These physical characteristics allow the unit's continuous belt to attract floating oil in the well. After picking up the oil, the belt travels over the head pulley on the drive unit and through tandem wiper blades. The oil is then scraped off both sides of the belt and discharged through a 1-1/4" ID hose. The unique bearingless design of the tail pulley (immersed in the well water) with its tethered frame allows it to perform three important functions: it keeps proper tension on the belt, prevents accidental loss down the well, and keeps the belt centered in the casing.

The PetroXtractor® can be installed in existing wells by mounting it on a flat surface above the well casing. Skimmer operation consists of merely lowering the belt and tail pulley into the casing until the pulley is fully immersed, placing the discharge hose in a container, and switching the unit on.

## The PetroXtractor Advantages

- Allows existing monitoring wells to be used as recovery wells
- Portable — can be easily hand-carried from site to site
- A single unit separates oil and elevates it up to 100 feet without a pump
- Skims very little water (unlike other skimmers and torpedo pumps)
- Maintains skimming efficiency with fluctuating water level
- Tail pulley is tethered to the frame to prevent accidental loss of belt and tail pulley in the well casing
- Easy mounting, fast cleaning with minimal maintenance
- Belt materials to fit any application

# PetroXtractor – Well Oil Skimmer

## Where To Use The PetroXtractor

The PetroXtractor is designed for those applications that have a limited access area and a deep drop between the mounting surface and the surface of the liquid. The unit can be used anywhere electric power or compressed air is available. Explosion proof and pneumatic motors are available for areas where combustible fumes may be present.

## Applications

- Groundwater monitoring wells
- Recovery wells
- Underground tanks

## Rugged Construction For Harsh Conditions

The PetroXtractor will provide for many years of trouble-free service. Belts are made of a specially engineered polymer, or a corrosion-resistant steel. A tough power train keeps the PetroXtractor running under the most severe conditions. With the proper configuration, the PetroXtractor can handle liquid temperatures up to 180 °F, and the pH of the fluid can range from 1 to 13.



*PetroXtractor on Mounting Stand with Oil Concentrator®*



*Tail Pulley Detail*

## Key Features of the PetroXtractor

- Small mounting and operating area
- Chip resistant powder coated finish
- Customized belt lengths and materials
- Easily mounted on flat surface
- Belt and wipers impervious to oils and fuels
- Weighted and tethered tail pulley
- Fast cleaning with minimal maintenance
- Can be customized to application needs

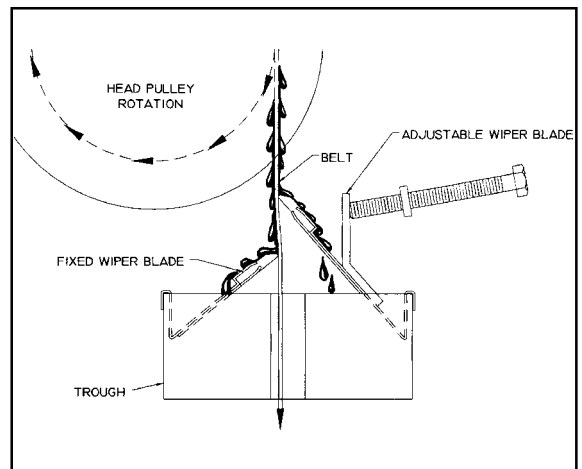

*Wiper Blade Detail*

## Installation Dimensions

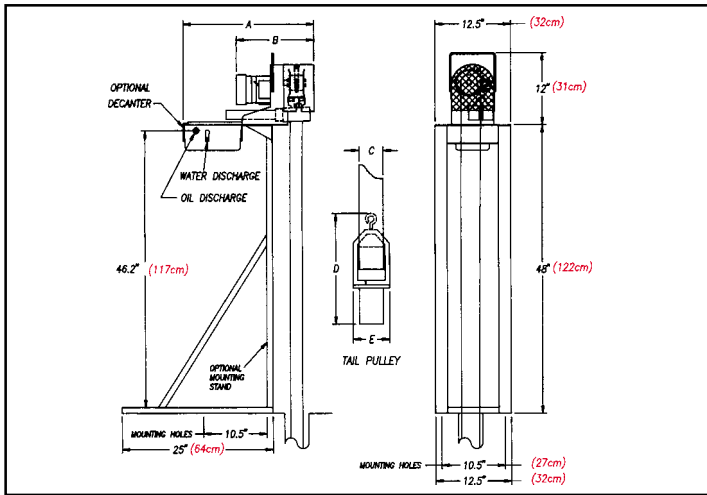

UNIT	A	B	C	D	E
1"	21 5/8" (55cm)	12 7/8" (33cm)	1" (2.5cm)	7 5/8" (19cm)	1 3/4" (4cm)
2"	21 5/8" (55cm)	12 7/8" (33cm)	1" (2.5cm)	7 5/8" (19cm)	1 3/4" (4cm)
4"	21 5/8" (55cm)	12 7/8" (33cm)	1" (2.5cm)	7 5/8" (19cm)	1 3/4" (4cm)

## Optional Below Grade Mounting Kit

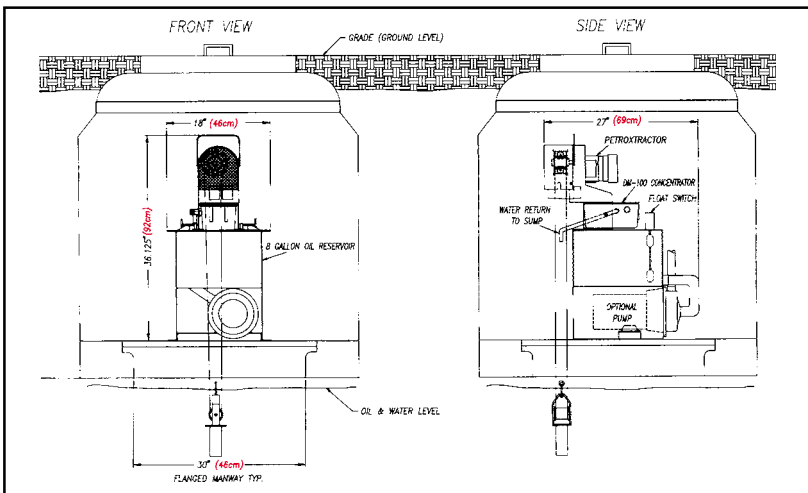

## Optional poly-shelter

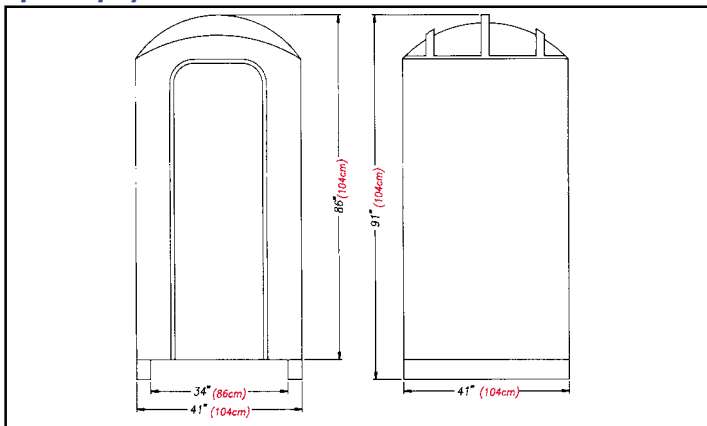

## Specifications:

**Oil Removal Rate** Model PX-A: 3 gph (11 lph) with 1 in. (2.5 cm) wide belt  
 Model PX-B: 6 gph (23 lph) with 2 in. (5 cm) wide belt  
 Model PX-C: 12 gph (45 lph) with 4 in. (10 cm) wide belt  
 (Removal rate is based on 30 weight oil in water.)

**Motor** Fractional hp TEFC, 115VAC, single phase, 60 Hz gear motor, including 8 foot cord with electrical plug  
 Optional: 50 Hz; 3-phase; explosion proof; 12VDC; and pneumatic

**Belt Width (Specify)** PX-A (1 in. (2.5 cm) for 2 in. (5 cm) ID casing  
 PX-B (2 in. (5 cm)) for 4 in. (10 cm) ID casing  
 PX-C (4 in. (10 cm)) for 6 in. (15 cm) ID casing

**Belt Length** User specified (See "Belt Selection" on back page.)

**Belt Material** Specify specially engineered polymer, or corrosion-resistant steel. (See "Belt Selection.")

**Wiper Material** CRV rubber

**Mounting Method** Flat base mount with oil discharge through a 1-1/4 in. (3.1cm) ID hose

**Mounting Area** See installation drawing.

**Weights<sup>1</sup>** Complete assembly without tail pulley or belt:  
 Model PX-A: 30 lbs. (13.6 Kg.)  
 Model PX-B: 31 lbs. (14 Kg.)  
 Model PX-C: 38 lbs. (17 Kg.)

PX-A Tail pulley: 2 lbs. ( 1.3 Kg.)  
 PX-B Tail Pulley: 3 lbs. ( 2.7 Kg.)  
 PX-C Tail Pulley: 4.5 lbs. (4.1 Kg.)

PX-A, 1 in. x 5 ft (1.5m) polymer belt: 0.55 lbs. (0.25 Kg.)  
 PX-B, 2 in. x 5 ft (1.5m) polymer belt: 1.1 lbs. (0.5 Kg.)  
 PX-C, 4 in. x 5 ft (1.5m) polymer belt: 2.2 lbs. (1.0 Kg.)  
 (Belt weight varies according to actual length specified.)

**Options (Specify)**

- Above-ground mounting stand
- Below grade mounting kit with reservoir and mounting bracket; transfer pump optional
- Stainless steel construction
- On-Off float switch to fit 3/4 in. (1.8 cm) bung of discharge drum
- Oil Concentrator® for virtually water-free oil discharge. (See back page.)
- Reinforced poly-shelters for durable protection of skimmer in outside applications
- 24 hour timer to start/stop PetroXtractor at specified intervals

**Standard Configuration** The Abanaki PetroXtractor is supplied with a head pulley guard, adjustable wiper blade assembly, skimmer belt, tail pulley, fractional hp, 110VAC, 60 Hz gear motor, and assembly/maintenance instructions.

**Specification Notes:**

1. The PetroXtractor is UPS shippable.
2. Consult factory for recommendations covering operating conditions not listed here.

## Belt Selection

**Belt Length.** To specify the belt length: Measure from the drive unit mounting plane to the surface of the liquid at its lowest level and add 12 inches (30.5 cm.)

**Belt Material.** Experience has shown that belt skimmers require a minimum square footage of space for installation, yet they surpass the requirements for most oil removal applications. The belt materials recommended in most applications for the PetroXtractor are specially engineered polymers. These polymers are ideal when physical abuse of the belt is likely, or where the skimmer is to be moved frequently. A corrosion-resistant steel belt also is available for applications where harsh chemicals are involved.

**When in doubt, consult factory for advice on the best belt for your application.**

**Abanaki has sold thousands of skimmers worldwide to leading companies such as ...**

American Cyanamid  
Armstrong World Industries  
Bethlehem Steel  
Boeing  
Bureau of Reclamation  
Caterpillar  
Chevron  
Clean Harbor Env. Eng.  
Corning  
Dow Chemical

Eaton  
Flying J  
Ford Motor  
General Electric  
Henry Filters  
Industrial Environmental Products  
John Deere  
Kaiser Aluminum  
Kemron Environmental  
Monroe Auto Equipment  
New York Power Authority

Nissan Motor  
Outboard Marine  
O.H.M. Corp.  
TRW  
United Airlines  
US Gypsum  
USS Repeating Arms  
USS Great Lakes Fleet  
Westinghouse Electric  
U.S. Army Corp. of Engrs.

## ABANAKI'S Oil Concentrators®

The Oil Concentrator® is an option available on all ABANAKI oil skimmers. Under most operating conditions ABANAKI oil skimmers will pick up oil with less than 5% water. But as surface oil is reduced to a thin layer (1/8 to 1/16 inch thick), more water may also be picked up along with the oil. When used in tandem with the oil skimmer, an Oil Concentrator will solve this problem, and provides virtually complete oil /water separation, saving money and improving the efficiency of the skimmer.

Based on the principle of gravity separation, the Oil Concentrator uses no electricity, timers, sensors, pumps, or other moving parts. The Oil Concentrator simply sits behind the skimmer and receives the skimmed effluent. The unit comes complete with a mounting bracket, removable sludge screen and a drain plug to ease clean up. For higher viscosity oils or low temperature applications, a thermostatically controlled heater is available as an option.

For more information, request Abanaki's Oil Concentrator bulletin.

# PetroXtractor® — Well Oil Skimmer

***For more information, please contact:***